

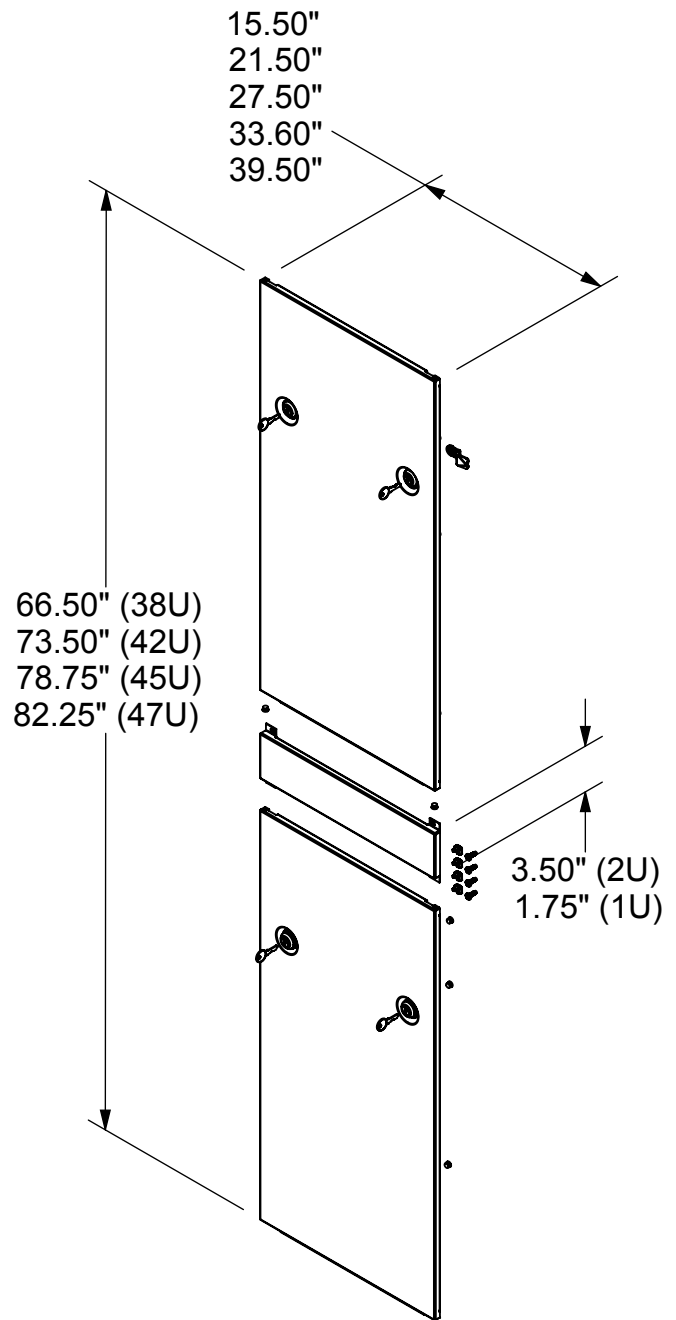

DESCRIPTION	WEIGHT (lbs)
38U X 24"D SOLID SPLIT SIDE PANEL	18.2
38U X 30"D SOLID SPLIT SIDE PANEL	24.4
38U X 36"D SOLID SPLIT SIDE PANEL	30.7
38U X 42"D SOLID SPLIT SIDE PANEL	36.9
38U X 48"D SOLID SPLIT SIDE PANEL	43.2
42U X 24"D SOLID SPLIT SIDE PANEL	19.8
42U X 30"D SOLID SPLIT SIDE PANEL	26.8
42U X 36"D SOLID SPLIT SIDE PANEL	33.7
42U X 42"D SOLID SPLIT SIDE PANEL	40.6
42U X 48"D SOLID SPLIT SIDE PANEL	47.5
45U X 24"D SOLID SPLIT SIDE PANEL	21.2
45U X 30"D SOLID SPLIT SIDE PANEL	28.6
45U X 36"D SOLID SPLIT SIDE PANEL	35.9
45U X 42"D SOLID SPLIT SIDE PANEL	43.4
45U X 48"D SOLID SPLIT SIDE PANEL	51.0
47U X 24"D SOLID SPLIT SIDE PANEL	22.1
47U X 30"D SOLID SPLIT SIDE PANEL	29.8
47U X 36"D SOLID SPLIT SIDE PANEL	37.5
47U X 42"D SOLID SPLIT SIDE PANEL	45.2
47U X 48"D SOLID SPLIT SIDE PANEL	52.9



- TWO (2) SOLID PANEL, 16GA
- CENTER SUPPORT BRKT, 16GA
- QUARTER TURN LATCH w/CAM
- SNAP IN BUMPER
- #12-24 CAGE NUT
- #12-24 x 5/8" DOG POINT SCREW
- FINISH: ACCESS GRAY (A)
BLACK POWDER (B)

VP	T	38	24	B
V-Line Side Panel	Style	Height (u)	Depth (in)	Color
VP	T Solid Split	38	24	A Gray
		42	30	B Black
		45	36	
		47	42	
			48	

THIS DRAWING AND/OR THE TECHNICAL INFORMATION CONTAINED HEREON IS THE PROPERTY OF COOPER B-LINE, INC. ("B-LINE"), AND IS ISSUED IN CONFIDENCE FOR B-LINE ENGINEERING PURPOSES ONLY AND MAY NOT BE REPRODUCED OR USED FOR ANY PURPOSE WHATSOEVER WITHOUT THE EXPRESS WRITTEN PERMISSION OF B-LINE TO THE USER. THIS DRAWING AND/OR TECHNICAL INFORMATION IS THE PROPERTY OF B-LINE AND IS LOANED FOR MUTUAL ASSISTANCE. TO BE RETURNED WHEN ITS INTENDED PURPOSE HAS BEEN SERVED.

 509 West Monroe St. Highland, IL 62249 Phone (800) 851-7415 FAX (800) 356-1438 www.cooperbline.com	SUBMITTAL DRAWING		REFERENCE DWG(S):	SUBMITTAL NO: S00016509
	TITLE: V-LINE SPLIT SIDE PANEL SOLID			DRAWN BY: SSINGH REV. A
				DATE: 05/18/09
	EQUIPMENT FURNISHED HAS BEEN FABRICATED IN ACCORDANCE WITH THIS DRAWING.		MODEL SOURCE FILE: 00016509	REV.: 00