

00014567

REVISION				
REV	DESCRIPTION	BY	DATE	CHANGE NO.
A	INITIAL RELEASE	DanC	5Jun07	BLR-NPR0680

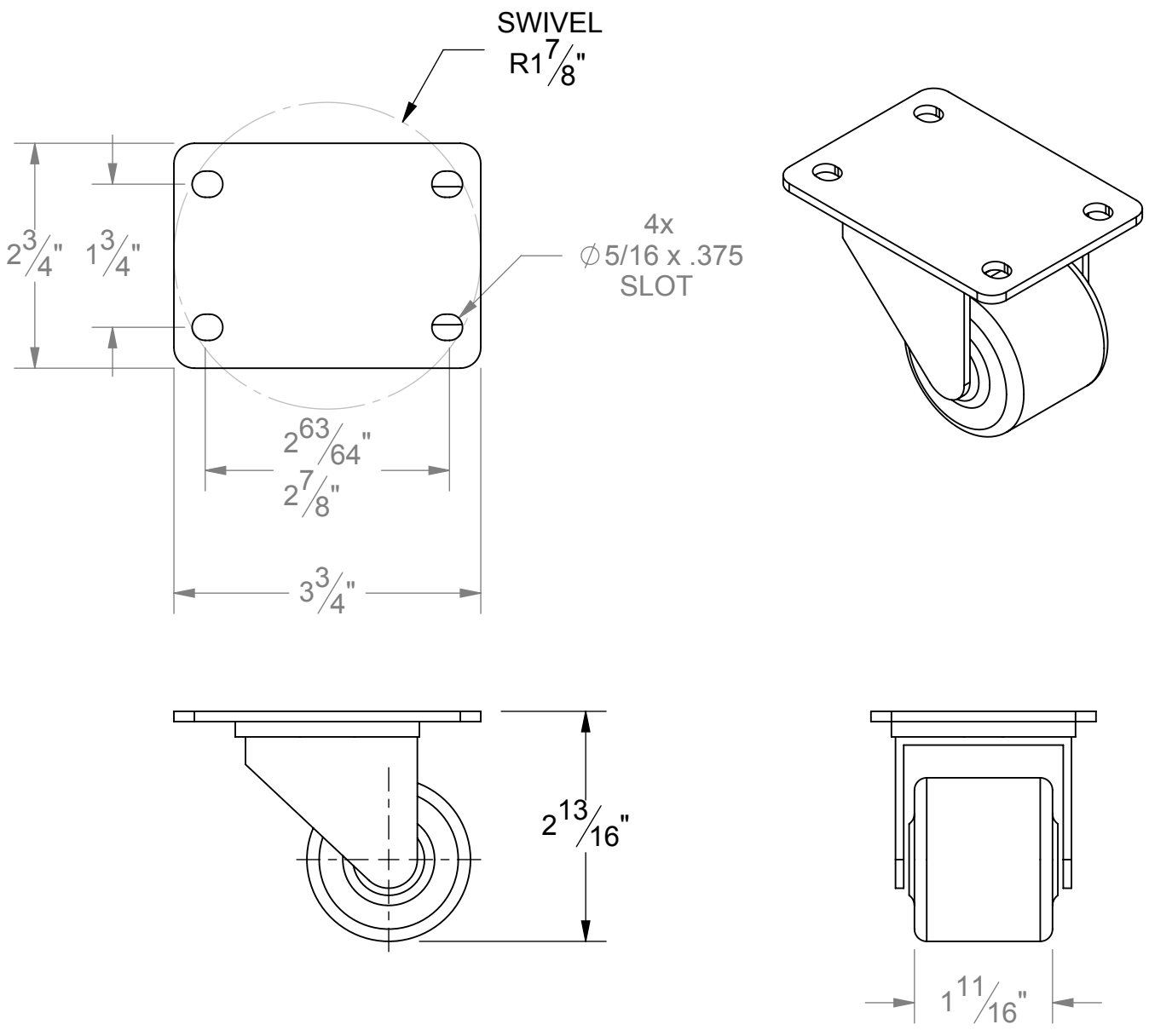

00014567	TRIO PINES CASTERS	TP8020-01-HDP	YES	
MATERIAL DESCRIPTION	MANUFACTURER	MFG. PART NO.	RoHS	

REV: 00	MATERIAL: <b>STEEL AXEL, BODY &amp; TOP PLATE PLASTIC WHEEL</b>	<small>TOLERANCES UNLESS OTHERWISE SPECIFIED:                  .XX ± .03                  .XXX ± .015                  FRACTION: ± 1/32                  ANGLE: ± 1°                  BENDS: ± 1°</small>		13755 Stead Blvd. Reno, NV 89506	
	FINISH: <b>BRIGHT ZINC</b>			TITLE: <b>00014567                  CASTER, TOP PLATE 2.75 x 3.75                  300#, 1.875 SWIVEL RADIUS                  TRIO PINES CASTERS</b>	
MODEL SOURCE FILE: 00014567	WT/PC: <b>1.80 LB</b>	<small>UNLESS OTHERWISE SPECIFIED, ALL DIMENSIONS ARE IN INCHES. ALL DIMENSIONS AND TOLERANCES ARE PER ASME Y14.5M-1994</small> <b>DO NOT SCALE DRAWING</b> <small>THIS DRAWING AND/OR THE TECHNICAL INFORMATION CONTAINED HEREON IS THE PROPERTY OF COOPER B-LINE, INC. ("B-LINE"), AND IS ISSUED IN CONFIDENCE FOR B-LINE ENGINEERING PURPOSES ONLY AND MAY NOT BE REPRODUCED OR USED FOR ANY PURPOSE WHATSOEVER WITHOUT THE EXPRESS WRITTEN PERMISSION OF B-LINE TO THE USER. THIS DRAWING AND/OR TECHNICAL INFORMATION IS THE PROPERTY OF B-LINE AND IS LOANED FOR MUTUAL ASSISTANCE. TO BE RETURNED WHEN ITS INTENDED PURPOSE HAS BEEN SERVED.</small>	DWG NO: <b>00014567</b>	REV: <b>A</b>	
		DRAWN BY: <b>DanC</b>	CHECKED BY:	DATE: <b>25Jan07</b>	SIZE: <b>A</b> SHEET: <b>1 OF 1</b>